

WEIGHT 760.56 KG / 1676.75 LBS

6% - 8% AIR ENTRAINED  
 35 MPa (5000 psi) @ 28 DAYS  
 AS PER CSA A23.4-09 STANDARD

ALL DIMENSIONS DEFAULT TO  
 MILLIMETERS  $\frac{\text{mm}}{[in]}$

10M REBAR TO BE USED THROUGHOUT  
 AND WELDED AT EVERY JUNCTION.

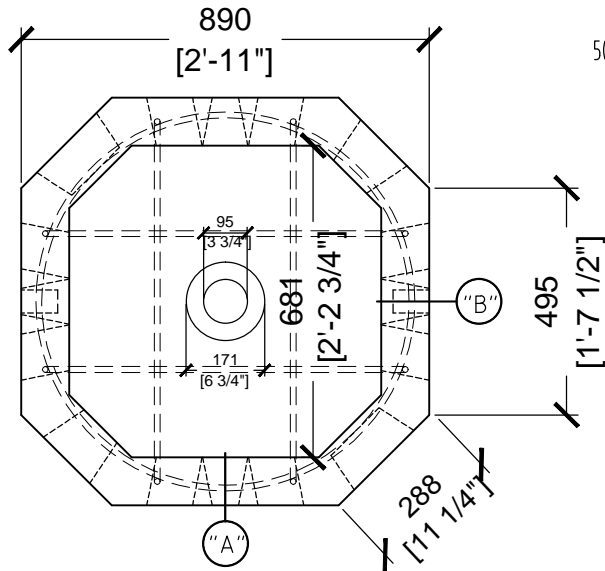

PLAN VIEW

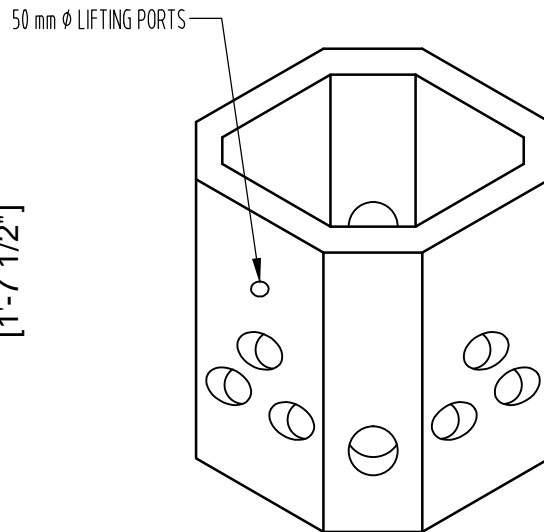

ISOMETRIC VIEW

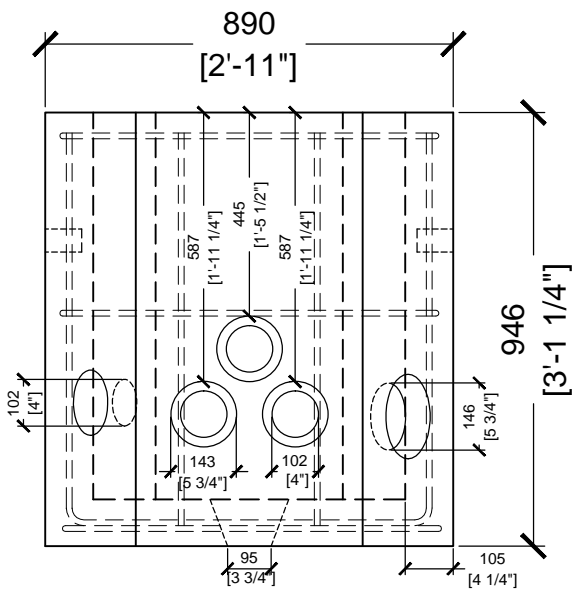

CROSS SECTION A

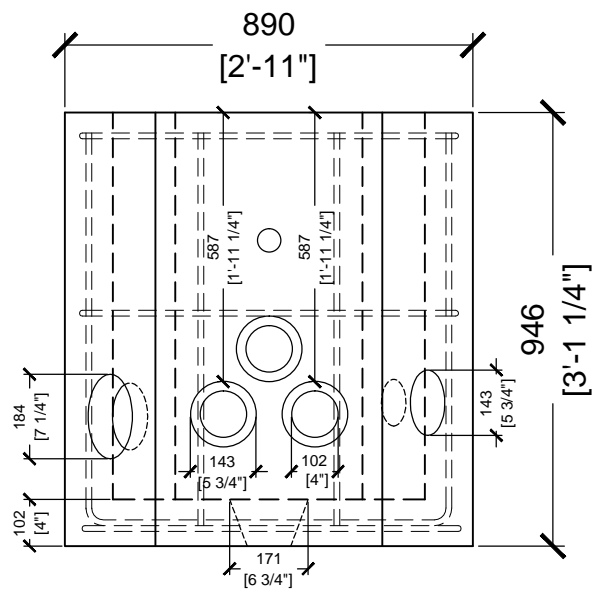

CROSS SECTION B

MOOSE CREEK CEMENT PRODUCTS (2006) LIMITED  
 ELECTRICAL TRAFFIC OCTAGONAL MANHOLE

NOT TO SCALE

DATE JUNE 2011

16525 SIXTH RD, MOOSE CREEK, ON  
 K0C 1W0  
 PHONE : (613)-538-2381  
 FAX : (613)-538-4870

